

SBT-140

Bin Tipper



Fits through standard doorways

Easily moved on casters

Stainless steel construction

Easily kept clean and hygienic for food service and medical environments

Battery operated

Typically needs charging weekly with universal ac input

Lift up to 70 kg (150 lb)

Safety mechanisms protect operator

Wide applications

Compatible with 2, 4, and 6 cubic yard dumpsters

The SBT-140 bin tipper is made of stainless steel so that it can be safely used in hospitals, food service operations, and other places that demand cleanliness and hygiene. The tipping mechanism is driven by a low pressure hydraulic mechanism that is safe and quiet.

The tipper is operated by batteries and is easily moved through any standard doorway. The entire tipper can be hosed down to maintain cleanliness.

The batteries typically provide a full week of operation between charges; a built-in battery meter indicates when charging is needed. A waterproof charger is incorporated that will typically recharge the batteries in five hours.

The tipper can be configured to handle USA bins up to 35 gallon and European and Australasian bins up to 140 litre. It can lift up to 70 kg (150 lb).



Safety features include: dual switches that require the operator to have hands on them at all times for operation; a red light and beeper on the opposite side to warn other personnel; a safety cutout switch with a removable key; and solid lockable wheels. Further, at all times the center of mass of the bin and its contents are within the footprint of the SBT bin tipper. The tipper can be equipped with optional side panels with a mesh screen and an interlocking door.

The SBT-140 bin tipper complements the Power Knot LFC-300 and LFC-500 biodigesters.

SBT-140

Description

Lifting capacity

70 kg (150 lb)

Acceptable bin types

EN 840-1: 60 (Type b) litre to 140 litre
ANSI Z245.60 (type B): 24 to 35 gallon

Determine bin type when ordering; bin capacity is adjusted on site. Can be changed from EN to ANSI types after purchase

Tipping time

25 seconds total to go up and down

Construction

All stainless steel (chassis, panels, chain, and wheels)

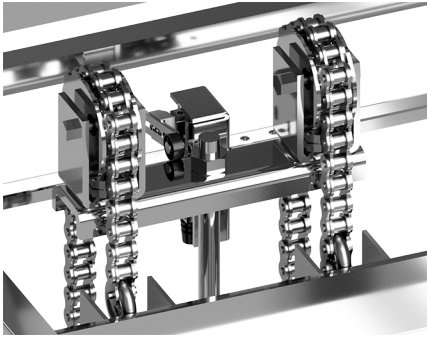

Floor surface flatness required

±15 mm (±0.6")

Weight without bin

155 kg (342 lb)

User control

Waterproof toggle switches: on-off and up-down

Safety features

Both toggle switches must be activated for tipper to operate (requires both hands on the control)



Red flashing light with beeper warns people nearby that SBT bin tipper is in use

Solid lockable casters

Emergency cut off switch



Cut off switch has removable key to prevent unauthorized use

Mass of bin is within footprint of SBT bin tipper at all times

System prevents operation when batteries are depleted

Available with a full cage with interlocking door

Operating environment

Indoors or outdoors

Operating temperature

-5°C to 40°C (23°F to 104°F)

Operating altitude

1000 m (3300 ft)

Ingress protection

IP54 – splash proof and dust proof



Batteries

Two of 22 Ah, 12 V, sealed lead acid AGM; won't leak if tipped over

Typical lifting capacity on full charge: 17 tonne (37,000 lb), or about 700 lifts

Battery indicator shows charge level and hours of use

Battery charging temperature

5°C to 35°C (41°F to 95°F) [ambient]

Battery charger

Waterproof charger incorporated

AC input connector is IEC 60320-1 C14 fused with two 6.3 A 5x20 mm fuses

Accepts standard ac power cord for your country

100~240 V, 50~60 Hz, 5 A, single phase

Typical charge time: 5 hours

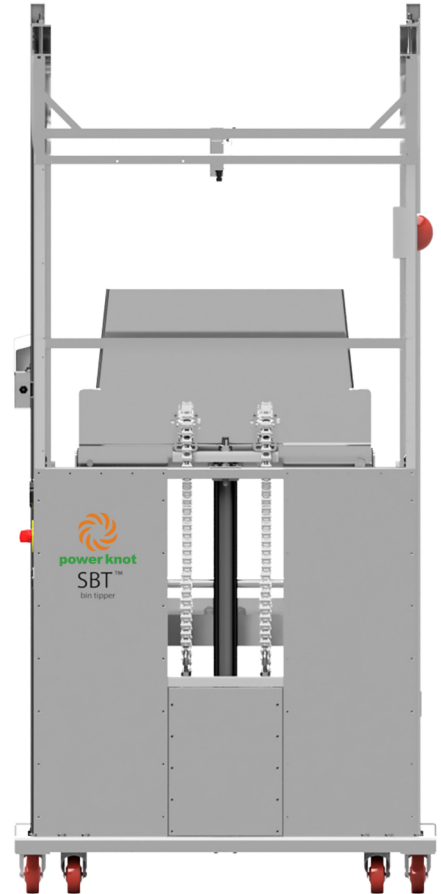

Moving and positioning

Machine is rolled into place with casters

Machine is locked in place by two front casters

Space required around machine

Left side: zero

Right side: 60 cm (24") for operator

Back: zero

Front: 60 cm (24") to load bin

Operating lifetime

Expected to be 15 to 25 years

Warranty

3 years on parts except batteries

RoHS

Compliant for EU and China

SBT-140

Dimensions in mm ± 2 mm

Bin shown is typical
140 litre. Dimension
to top of bin depends
on size of bin.

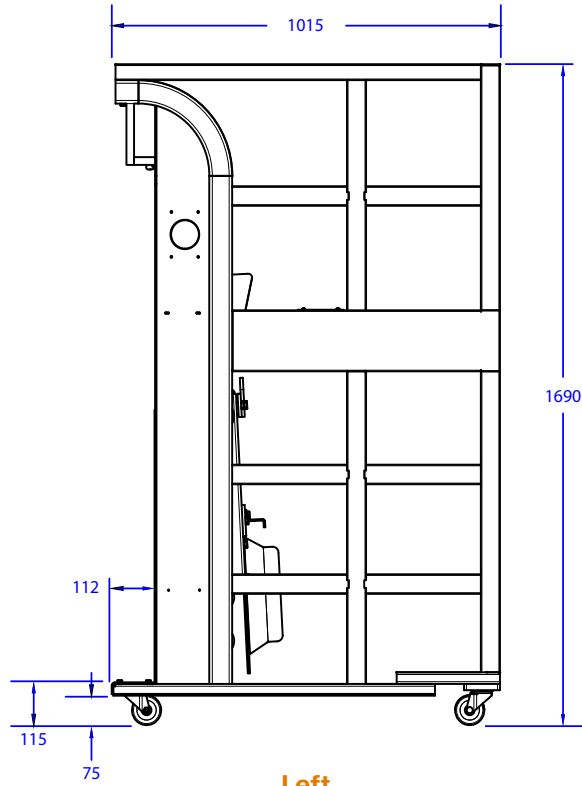

Left

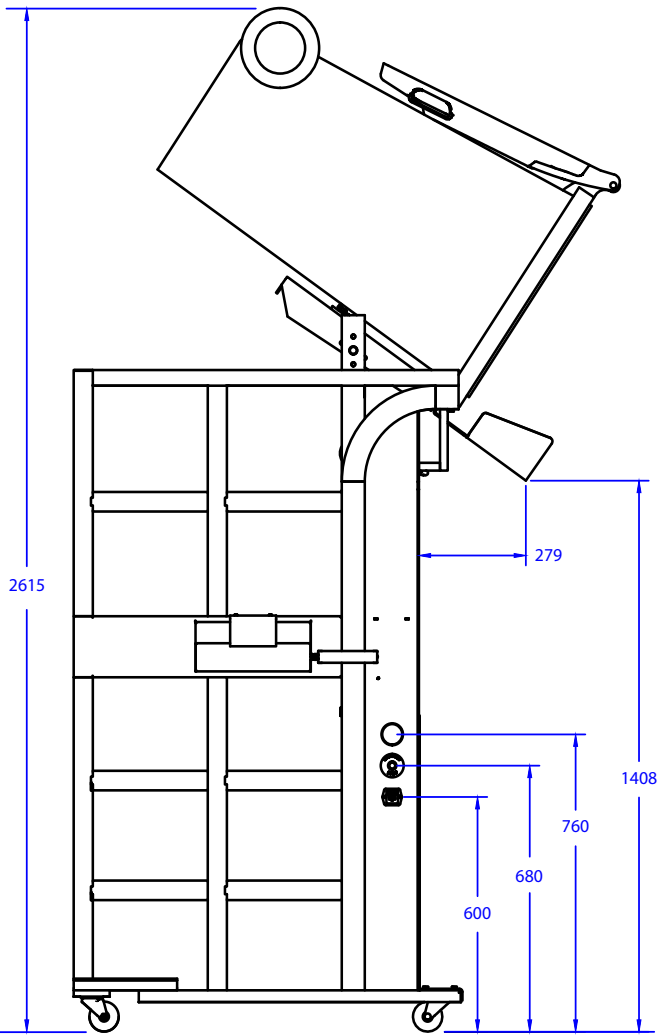

Right with bin fully lifted

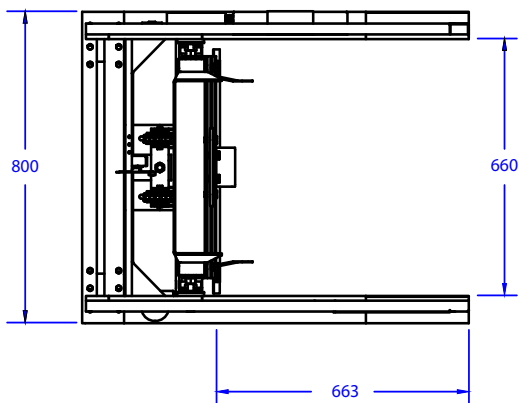

Top

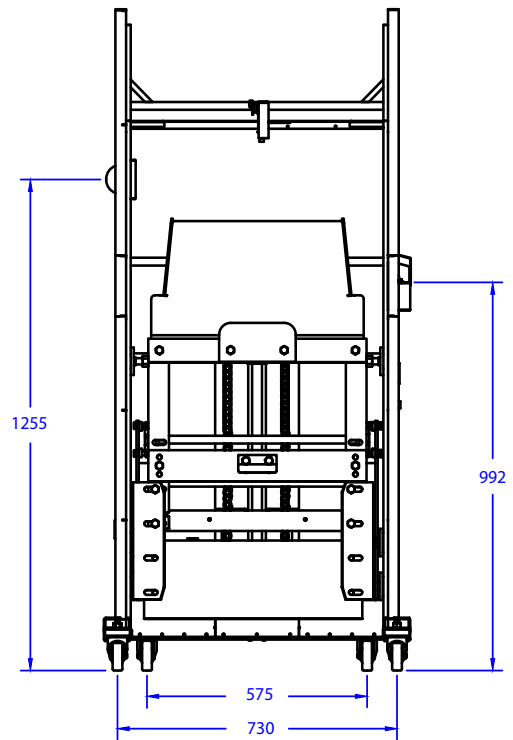

Front

SBT-140

Dimensions in inches ± 0.1 "
(derived from mm)

Bin shown is typical
35 gallon. Dimension
to top of bin depends
on size of bin.

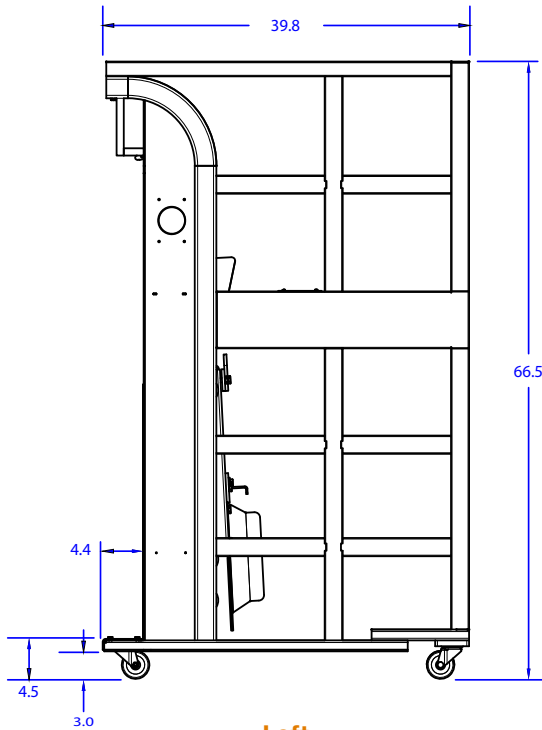

Left

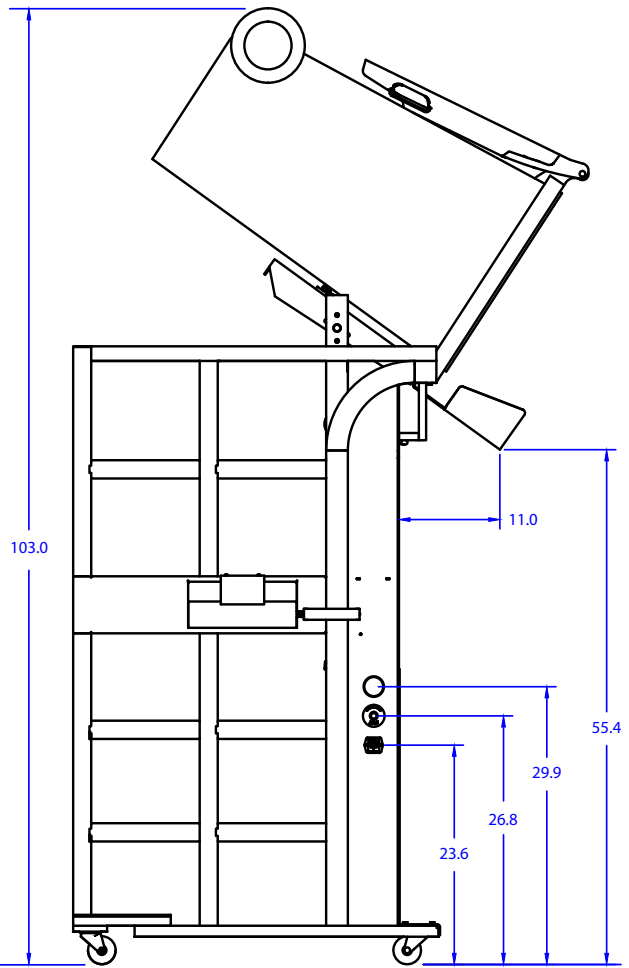

Right with bin fully lifted

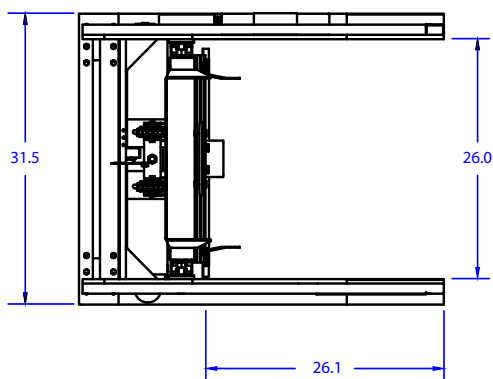

Top

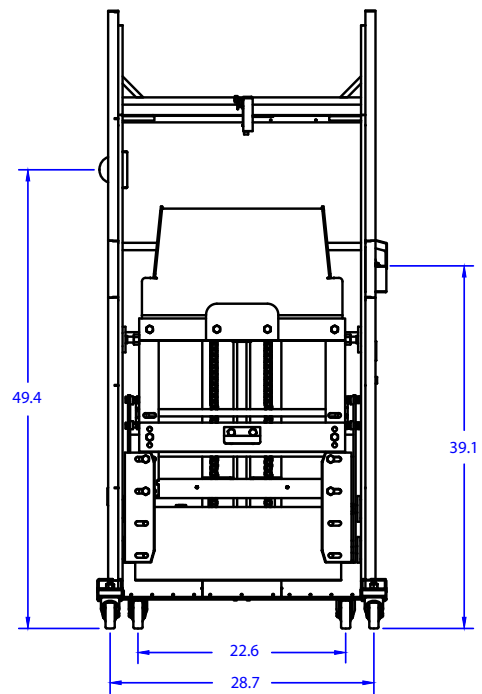

Front



Power Knot LLC | 47613 Warm Springs Blvd | Fremont, CA 94539 USA | +1-408-889-8433 | info@powerknot.com | www.powerknot.com

Power Knot, the Power Knot logo, the Power Knot mark, LFC, LFC Cloud, and SBT are trademarks or registered trademarks of Power Knot LLC. All other trademarks used herein are the property of their respective owners. Copyright © 2018–2024 Power Knot LLC; all rights are reserved. Specifications are subject to change at any time without notice. Document number 96-01050-11, 02 July 2024.