

SBH-180™

Lug cart



Description

The SBH-180 lug cart is an industrial lug cart that is used in demanding environments where stability, longevity, robustness, and reliability are critical.

Constructed of stainless steel, the SBH-180 lug cart can reliably be used in kitchens and galleys to transport a variety of products including parts, cutlery and dishes, food stuffs, and organic waste. The cart is supplied with six polypropylene bins.

For stability, each wheel can be locked so that on a ship, for example, the cart will not roll around on its own. There is a mechanism that prevents bins from sliding out on the opposite side from where loaded. This can easily be disabled or enabled.

This product is ideally suited for cruise ships and commercial food preparation businesses. It is designed and developed by Power Knot in Silicon Valley, California.

Features

- Made of stainless steel so it can safely be used in kitchens and galleys
- Meets USPH and NSF requirements
- Rigid construction tolerates heavy duty usage
- Double lip bin runners support heavy bins and allow easy access
- 6 bins accommodate significant weight of items
- Bins can be easily washed and stacked when not in use
- Four 360° stainless steel swivel casters each 125 mm (5") with foot lock and release
- Bins can be loaded from either side, or rear stop mechanism prevents bins from sliding out from non working side
- Rear stop mechanism is easily engaged or disengaged
- Fits through all standard doors on ships and commercial buildings, including crew elevators
- Lay flat packaging for shipment makes transportation and storage low cost and easy



Benefits

- Minimize lifting and carrying by personnel to prevent injuries
- Safely transport waste food from galley or kitchen to Power Knot LFC biodigesters, even when on different decks or levels
- Durable cart that will survive being knocked into elements in the kitchen or galley
- Cart is sanitary and easy to clean
- Construction will not rust
- Maneuvers easily and can be used by existing staff
- 3 year warranty

SBH-180

Details

Construction

All stainless steel chassis

Weight when empty

56 kg (123 lb) without bins

60 kg (132 lb) with bins

Carrying capacity

30 kg (66 lb) per bin

180 kg (397 lb) for the full cart

Weight when full

240 kg (529 lb) maximum

Operating lifetime

Expected to be 15 to 25 years

Bins

Grey or yellow polypropylene

Warranty

3 years on all parts and components
(1 year for marine, security, and rentals)

Subject to terms and conditions

Dimensions in mm \pm 2 mm (inch \pm 0.1")

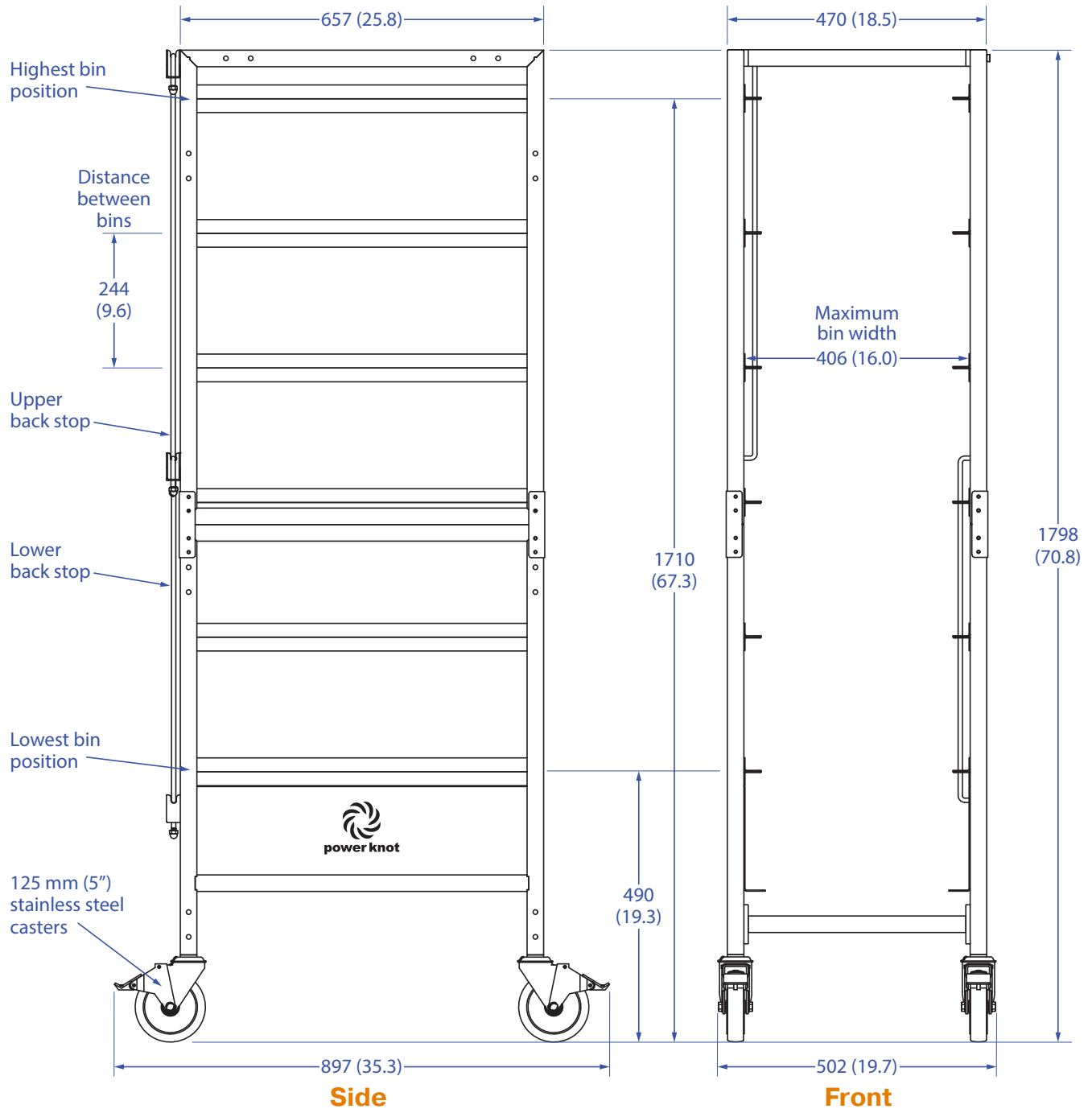

Power Knot LLC | 47613 Warm Springs Blvd | Fremont, Ca 94539 USA | +1-408-889-8433 | info@powerknot.com | www.powerknot.com

Power Knot, the Power Knot logo, the Power Knot mark, LFC, and SBH-180 are trademarks or registered trademarks of Power Knot LLC. All other trademarks used herein are the property of their respective owners. Copyright © 2009–2024 Power Knot LLC; all rights are reserved. Specifications are subject to change at any time without notice. Document number 96-01212-06, 30 August 2024.