

LFC-70

Biodigester

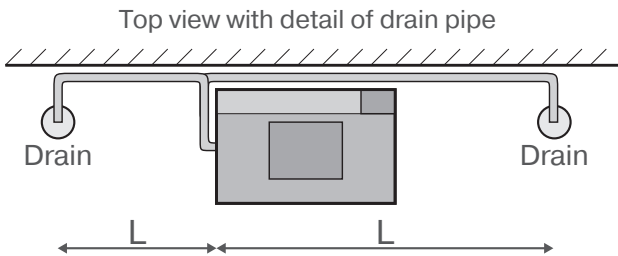

Only one drain is required on left side or right side of machine
Pipes normally run along wall for neatness, but can be direct
L = length of pipe run: 400 cm (160") maximum; 3 of 90° bends maximum; do not run pipes under the biodigester

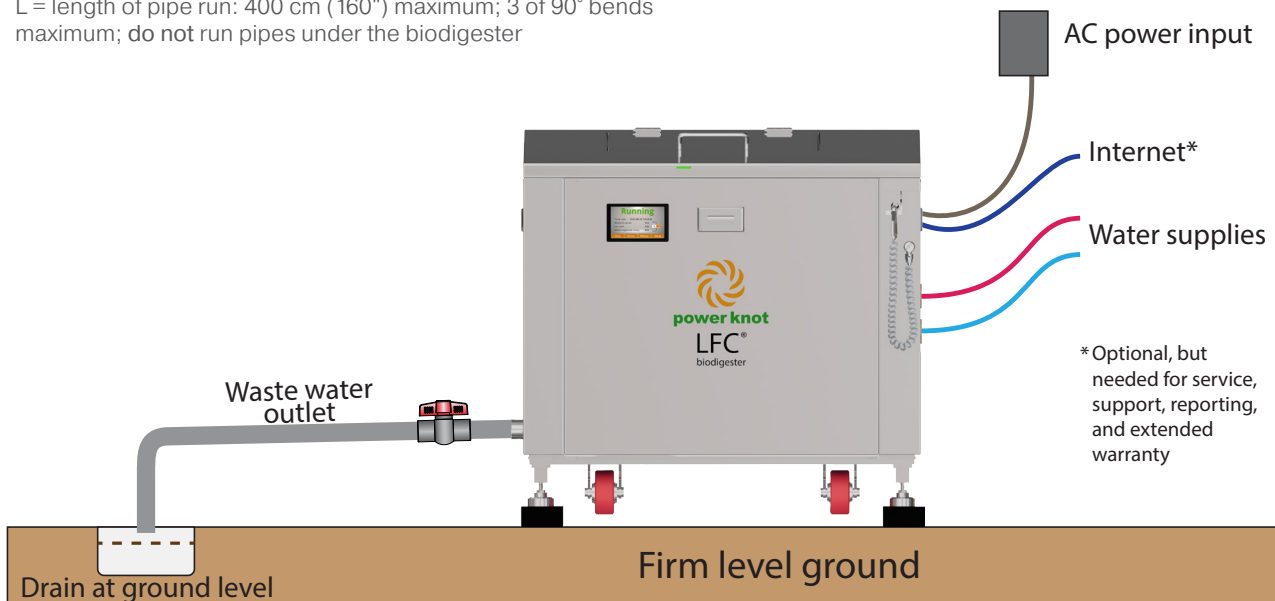

LFC-70

Installation Requirements

Maximum capacity of food waste

70 kg (154 lb)
90 litre (20 gallon)

Digestion of food waste per day

25 kg to 210 kg (55 lb to 460 lb)

Construction

All stainless steel (chassis, side panels, drum, shaft, arms, paddles, and load cells). Chassis is mirror finish (EN 10088-2 specification 2P)

Operating environment

Indoors or covered patio

Must not be exposed to rain, snow, or sunshine

Ingress protection

IP54 – splash proof and dust proof

Operating altitude

0 to 3000 m (9800 ft)

Ambient operating temperature

10°C to 40°C (50°F to 104°F) when altitude is less than 1000 m (3300 ft); reduce linearly to 24°C (75°F) at 3000 m

Floor surface flatness required

±5 mm (±0.2")

Weight when empty

204 kg (450 lb)

Moving and positioning

Machine is rolled into place with casters
Machine is raised once in position and supported by feet and rubber pads

Weight when full

309 kg (681 lb) maximum

Load per pad

104 kg (229 lb) maximum

Pressure per pad

100 kPa (15 psi), maximum

Space required around machine

Left side: 20 cm (8") minimum, 30 cm (12") preferred. 100 cm (39") is required for servicing

Right side: 15 cm (6") minimum, 60 cm (24") preferred. 125 cm (50") is required for servicing

Back: 2 cm (1")

Front: 60 cm (24") minimum

Water inlets

Filters: use external filters to remove particles and hardness

Fittings: DN 15 (½") female
Use flexible hose pipes to allow machine to move freely. Install valves to disconnect

water for servicing and backflow prevention devices if required

Pressure: 275 to 675 kPa
(40 to 98 psi, 2.8 to 6.9 kg/cm²)

Flow rate: 20 litre per minute (5 gpm) max.
@ 450 kPa (65 psi, 4.5 kg/cm²)

Drum water: 42°C~50°C (108°F~120°F)

Washout water: 15°C~75°C (60°F~165°F)

Use WMX-20 water system or use external mixing valves, heaters, pressure reducers, and bladder tanks to meet the above requirements as needed

Water input per day

210 litre (55 gallon) typical

Water outlet

Use flexible coupling on output to permit machine to move freely

Install stop valve on outlet pipe (used for commissioning)

Slope pipe down by about 1 in 45 (1.3°)

Drain

Type: Must exit to sewer (not storm drain); grease trap is required in most jurisdictions

Size: 50 mm (2") minimum

Total water output per day

280 litre (74 gallon), typical

Flow rate of waste water out

20 l/min (5.4 gpm), maximum
0.2 l/min (0.05 gpm), typical average

AC supply

Single phase (L+N+ PE)
100 V to 260 V, 50 Hz to 60 Hz
IEC 60320-1 C 14 socket
External circuit breaker: 8 A

AC power cord

Order power cord separately. Typical length of power cord: 180 cm (6')

Facility power outlet must be accessible by operator and have a safety disconnect

Maximum power

380 W

Electrical energy per day

1.9 kWh typical

Heat generated by digestion

70 W to 210 W, 140 W typical

User interface

22 mm 3-color LED

5" touchscreen with 65k colors

Ethernet

RJ45, 100 baseT
DHCP or fixed IP address

Connect to Internet with direct cable, Wi-Fi client, or GSM modem

Automatically connects to LFC Cloud for remote support, reporting, and monitoring (included in purchase price)

Powerzyme

Microorganisms and enzymes

0.7 litre, included with initial purchase

Powerchips

Medium for microorganisms

70 litre, included with initial purchase

Operating lifetime

Expected to be 15 to 25 years

Warranty

3 years on all parts and components
(1 year for marine, security, and rentals)
Subject to terms and conditions

Hygiene

NSF/ANSI 13-2024

Weighing

NTEP certified to NIST Handbook 44

Safety

Certified to UL430 edition 8
(waste disposal machines)
CAN/CSA-C22.2 No. 60335-1-11 R16
CAN/CSA-C22.2 No. 60335-2-16:16
EN 60335-1:2012+A11:2014+A13:2017
+A1:2019+A14:2019+A2:2019
EN 60335-2-16:2003+A1:2008+A2:2012
+A11:2018

EMC and EMI

47 CFR FCC part 15, subpart B, class B
ICES-003:2016 Issue 6, class B
ANSI C63.4:2014
EN 61000-6-1:2007 & 2005
EN 61000-6-3:2007+A1:2011 & 2006
CISPR 16-2-3:2016
CISPR 16-2-1:2006
CISPR 16-1-2:2003 + A1:2004 + A2:2006
EN 61000-3-2:2005 +A1:2008 +A2:2009
EN 61000-3-3:2013
EN 61000-4-2:1995
EN 61000-4-3:2006
EN 61000-4-4:2004
EN 61000-4-5:2006
EN 61000-4-6:2014
EN 61000-4-8:1993
EN 61000-4-11:2004

EU directives

Low Voltage Directive: 2014 / 35 / EU
EMC Directive: 2014 / 30 / EU
RoHS Directive: 2011 / 65 / EC
WEEE Directive: 2012 / 19 / EC



For complete details see User's Manual

LFC-70

Dimensions in mm ±2 mm

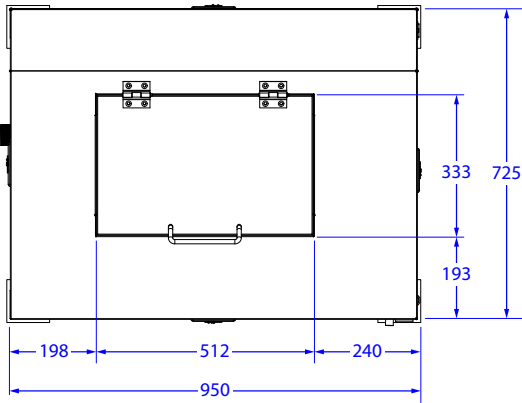

Top

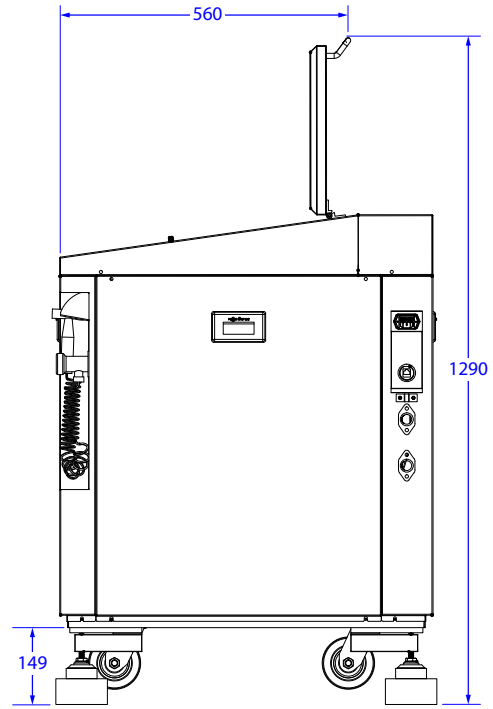

Right with door fully open

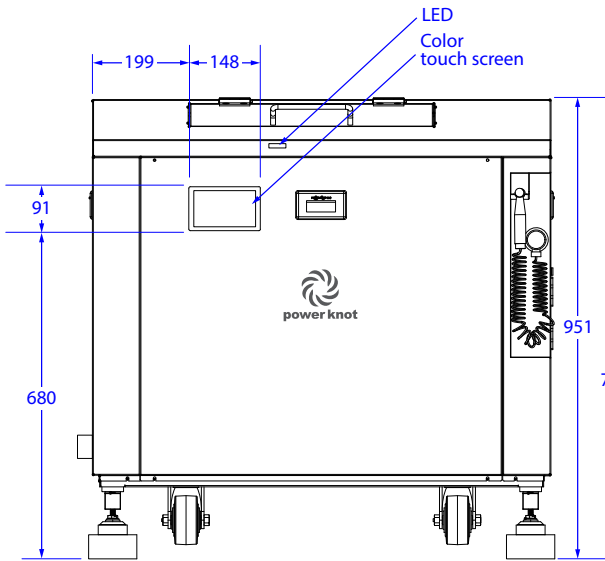

Front

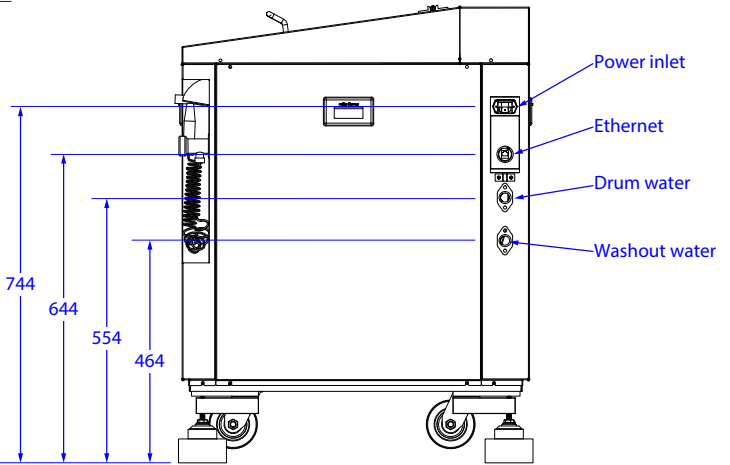

Right

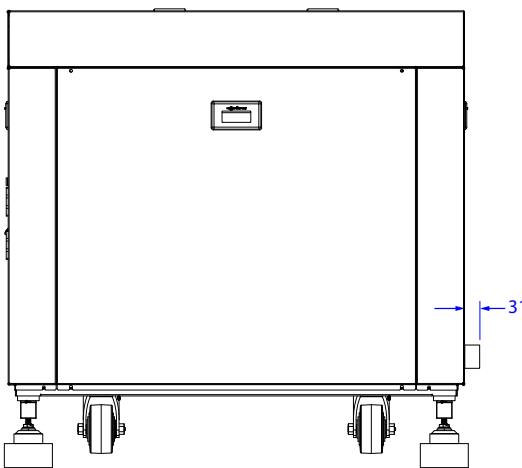

Back

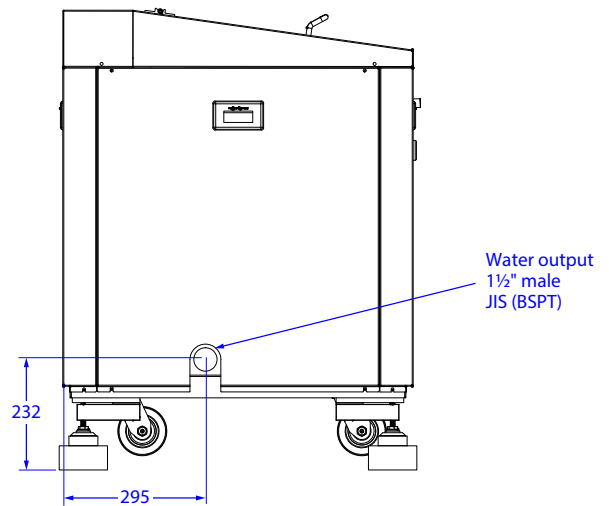

Left

LFC-70

Dimensions in inches ±0.1"
(derived from mm)

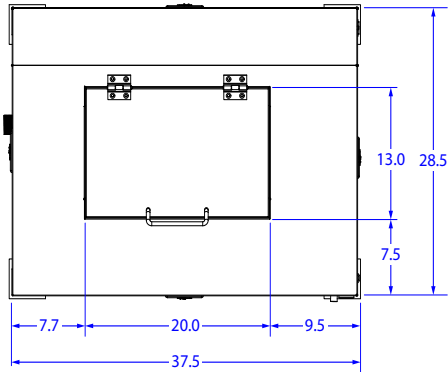

Top

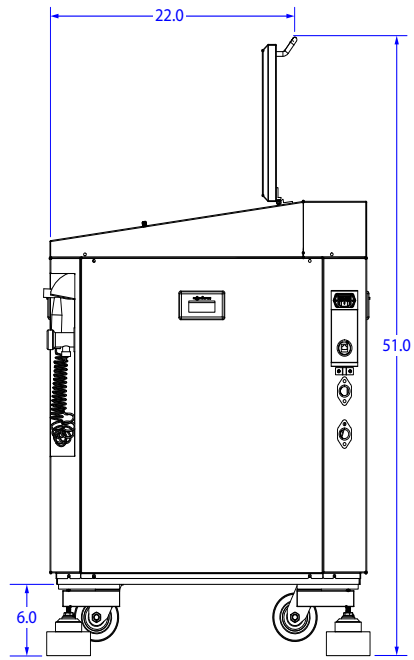

Right with door fully open

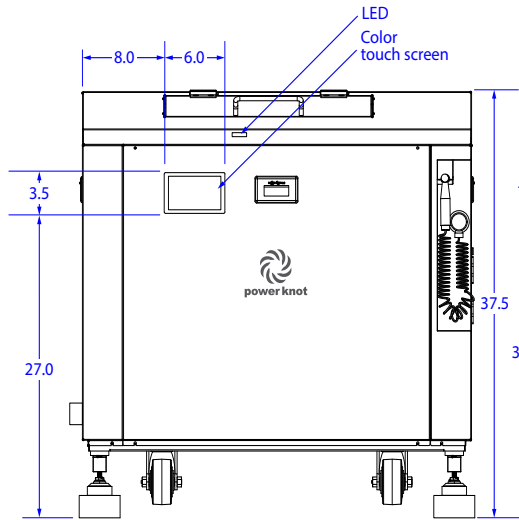

Front

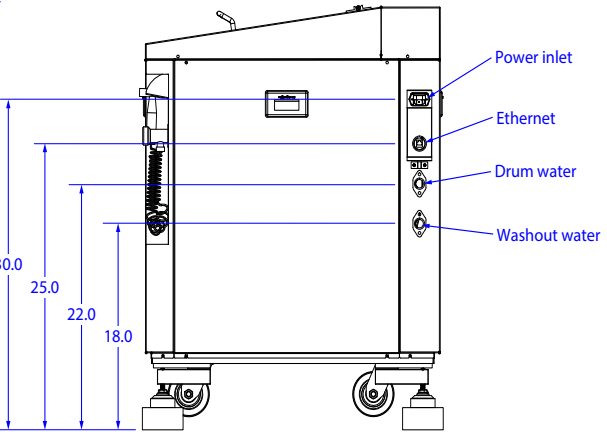

Right

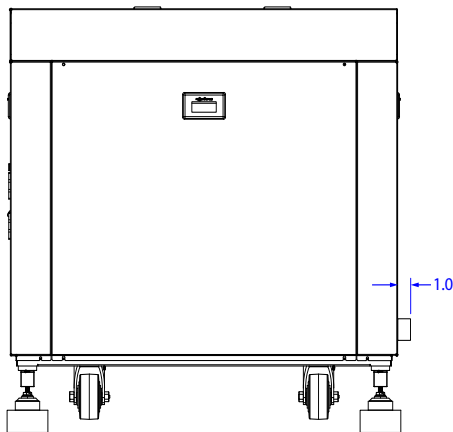

Back

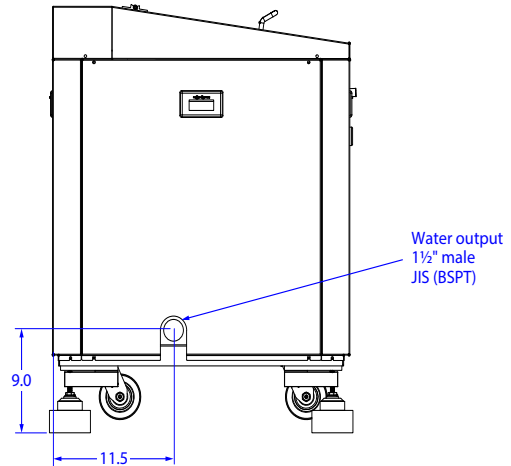

Left



Power Knot LLC | 47613 Warm Springs Blvd | Fremont, CA 94539 USA | +1-408-889-8433 | info@powerknot.com | www.powerknot.com

Power Knot, the Power Knot logo, the Power Knot mark, LFC, LFC Cloud, Powerchips, and Powerzyme are trademarks or registered trademarks of Power Knot LLC. All other trademarks used herein are the property of their respective owners. Copyright © 2009–2026 Power Knot LLC; all rights are reserved. Specifications are subject to change at any time without notice. Document number 96-01035-45, 21 April 2026.