

# LFC-1000

Biodigester

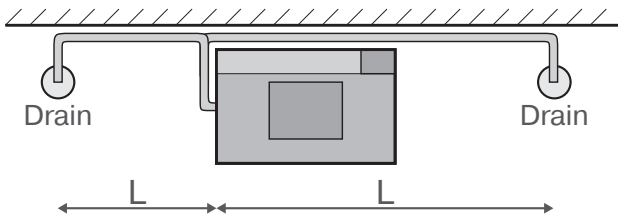

Top view with detail of drain pipe



Only one drain is required on left side or right side of machine  
Pipes normally run along wall for neatness, but can be direct  
L = length of pipe run: 400 cm (160") maximum; 3 of 90° bends maximum; do not run pipes under the biodigester

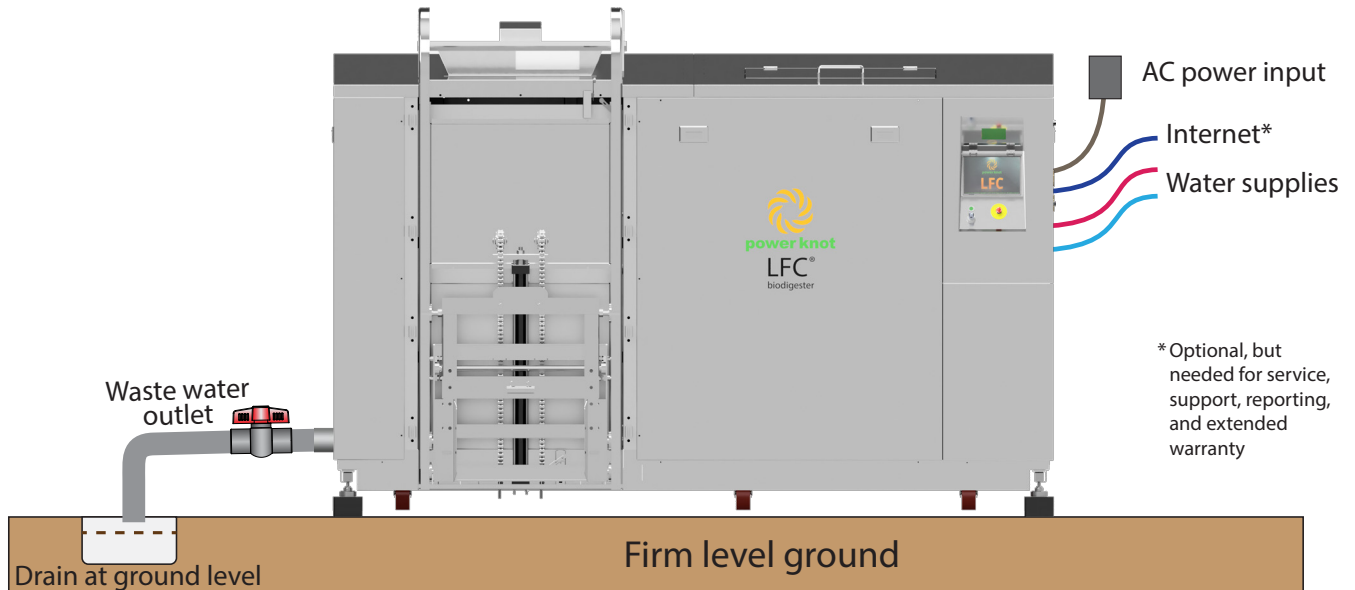

# LFC-1000

## Installation Requirements

### Maximum capacity of food waste

1000 kg (2200 lb)  
1250 litre (320 gallon)

### Digestion of food waste per day

350–3000 kg (770–6600 lb) typical

### Construction

All stainless steel (chassis, side panels, drum, shaft, arms, paddles, and load cells). Chassis is mirror finish (EN 10088-2 specification 2P)

### Operating environment

Indoors or covered patio  
Must not be exposed to rain, snow, or sunshine

### Ingress protection

IP54 – splash proof and dust proof

### Operating altitude

0~3000 m (9800 ft)

### Ambient operating temperature

10°C~40°C (50°F~104°F) when altitude is less than 1000 m (3300 ft); reduce linearly to 24°C (75°F) at 3000 m

### Floor surface flatness required

±5 mm (0.2")

### Weight when empty

1330 kg (2930 lb)

### Moving and positioning

Machine is rolled into place with casters  
Machine is raised once in position and supported by feet and rubber pads

### Weight when full

2850 kg (6280 lb) maximum

### Load and pressure per pad

950 kg (2100 lb) maximum  
414 kPa (60 psi), maximum

### Inlet port

DN 115 sanitary fitting; supplied with bellows terminated in DN 100 sanitary fitting. Relay output signals to host system capacity of LFC biodigester

### Bin lifter and NFC cards

Maximum lift: 70 kg (155 lb)

Different models accept:

**ANSI Z245.60** Type B (N. America)

24, 32, and 35 gallon roller bins

**EN 840-1** Type b (rest of world)

60, 80, 120, and 140 litre wheelie bins

Bin lifter and automatic door are activated by an NFC card. Can use up to 100 different registered NFC cards

### Space required around machine

**Left side:** 40 cm (16") minimum, 60 cm (24") preferred. 100 cm (39") is required for servicing

**Right side:** 40 cm (16") minimum, 60 cm (24") preferred. 150 cm (60") is required for servicing

**Back:** 10 cm (4")

**Front:** 150 cm (60") minimum

### Water inlets

**Filters:** filters are mounted on machine to remove particles

**Fitting:** DN 15 (½") female

Use flexible hose pipes to allow machine to move freely. Install valves to disconnect water for servicing and backflow prevention devices if required

**Pressure:** 275 to 675 kPa  
(40 to 98 psi, 2.8 to 6.9 kg/cm<sup>2</sup>)

**Flow rate:** 20 litre per minute (5 gpm) max.  
@ 450 kPa (65 psi, 4.5 kg/cm<sup>2</sup>)

**Hot:** 45°C~80°C (113°F~176°F)

**Cold:** 5°C~45°C (41°F~113°F)

### Water input per day

3000 litre (800 gallon) typical

### Water outlet

Typically use flexible coupling on output to permit machine to move freely

Install stop valve on outlet pipe (used for commissioning)

Slope pipe down by about 1 in 45 (1.3°)

### Drain

**Type:** Must exit to sewer (not storm drain); grease trap is required in most jurisdictions

**Size:** 100 mm (4") minimum

### Total water output per day

4000 litre (1050 gallon), typical

### Flow rate of waste water out

26 l/min (7 gpm), maximum

2.8 l/min (0.7 gpm), typical average

### AC supply (order one type)

**Without neutral (3L+PE), 50 Hz or 60 Hz**

**208 V:** 187 V to 230 V

**250 V:** 230 V to 260 V

**With neutral (3L+N+PE), 50 Hz or 60 Hz**

**400 V:** 360 V to 440 V

**440 V:** 400 V to 480 V

External circuit breaker required: 15 A

### AC power outlet

Can wire directly (without a plug and socket). Facility power outlet must be accessible by operator and have a safety disconnect

Emergency switch is fitted on chassis

### AC power cord

Length of cable on machine: 180 cm (6');

L15-20 plug fitted on 208 V machine; no plug on other options

### Maximum ac power

4.9 kW

### Electrical energy per day

29 kWh typical

### Heat generated by digestion

1 kW ~ 4 kW, 2 kW typical

### User interface

22 mm 3-color LED

7" touchscreen with 65k colors

### Ethernet

RJ45, 100 baseT

DHCP or fixed IP address

Connect to Internet with direct cable, Wi-Fi client, or GSM modem

Automatically connects to LFC Cloud for remote support, reporting, and monitoring (included in purchase price)

### Relay signals

SD13-3 connector to indicate LFC-1000 status to external equipment

### Powerzyme

Microorganisms and enzymes

10 litre, included with initial purchase

### Powerchips

Medium for microorganisms

1000 litre, included with initial purchase

### Operating lifetime

Expected to be 15 to 25 years

### Warranty

3 years on all parts and components

(1 year for marine, security, and rentals)

Subject to terms and conditions

### Hygiene

NSF/ANSI 13-2024

### Weighing

NTEP certified to NIST Handbook 44

### Safety

Certified to UL430 edition 8

(waste disposal machines)

CAN/CSA-C22.2 No. 60335-1-11 R16

CAN/CSA-C22.2 No. 60335-2-16:16

EN 60335-1:2012+A11:2014+A13:2017

+A1:2019+ A14:2019+A2:2019

EN 60335-2-16:2003+A1:2008+A2:2012

+A11:2018

### EMC and EMI

47 CFR FCC part 15, subpart B, class B

ICES-003:2016 Issue 6, class B

ANSI C63.4:2014

EN 61000-6-1:2007 & 2005

EN 61000-6-3:2007+A1:2011 & 2006

CISPR 16-2-3:2016

CISPR 16-2-1:2006

CISPR 16-1-2:2003 + A1:2004 + A2:2006

EN 61000-3-2:2005 +A1:2008 +A2:2009

EN 61000-3-3:2013

EN 61000-4-2:1995

EN 61000-4-3:2006

EN 61000-4-4:2004

EN 61000-4-5:2006

EN 61000-4-6:2014

EN 61000-4-8:1993

EN 61000-4-11:2004

### EU directives

Low Voltage Directive: 2014 / 35 / EU

EMC Directive: 2014 / 30 / EU

RoHS Directive: 2011 / 65 / EC

WEEE Directive: 2012 / 19 / EC



For complete details see User's Manual

# LFC-1000

Dimensions in mm ±2 mm

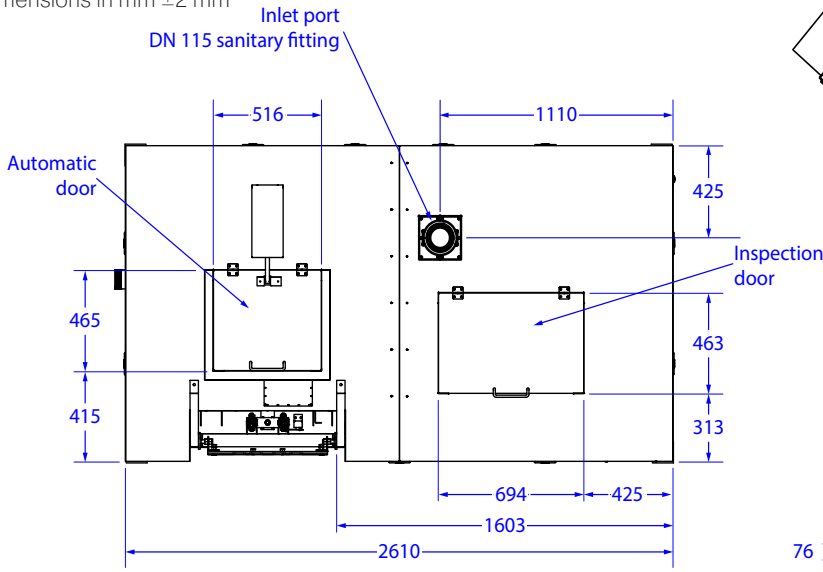

Top

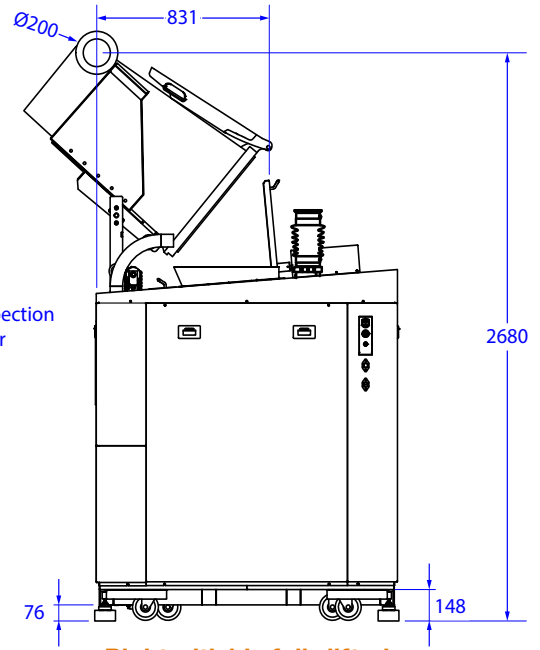

Right with bin fully lifted

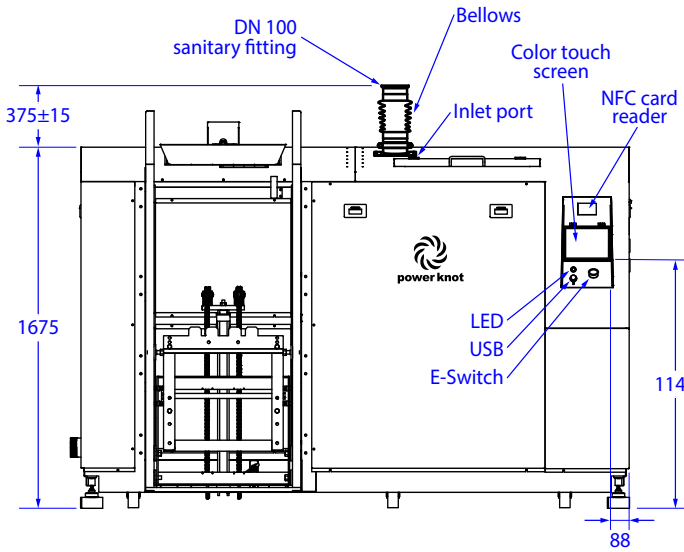

Front

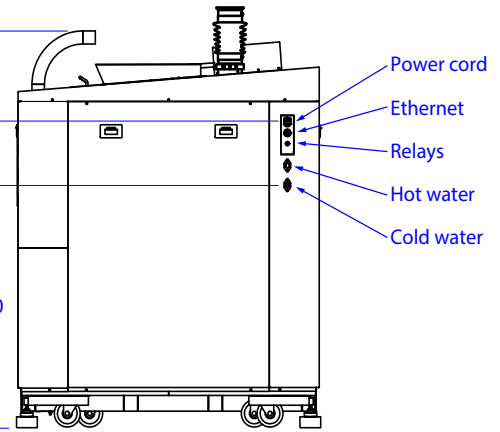

Right

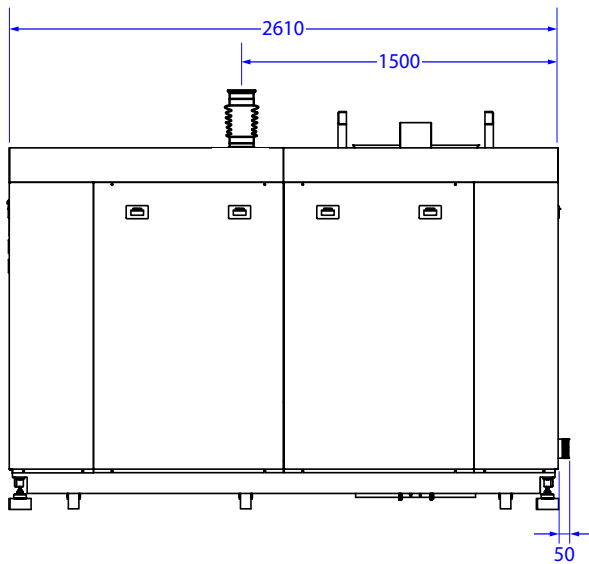

Back

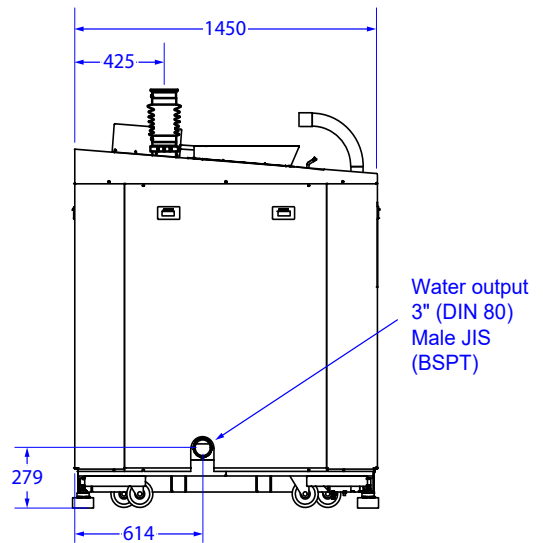

Left

# LFC-1000

Dimensions in inches ±0.1"  
(derived from mm)

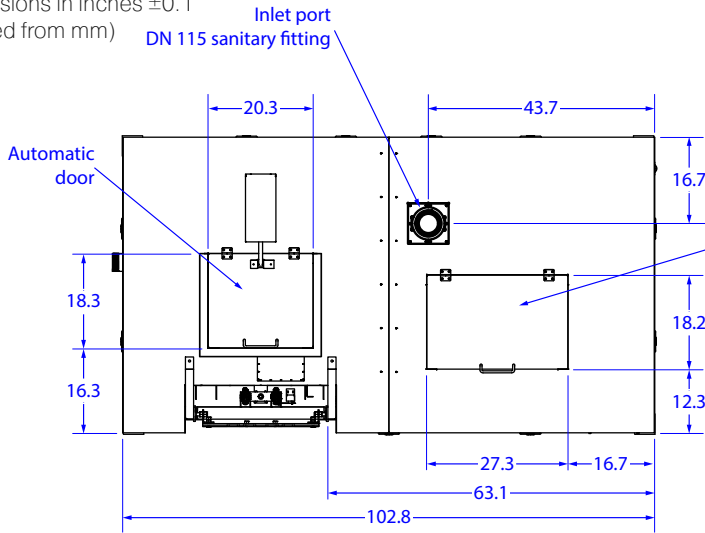

Top

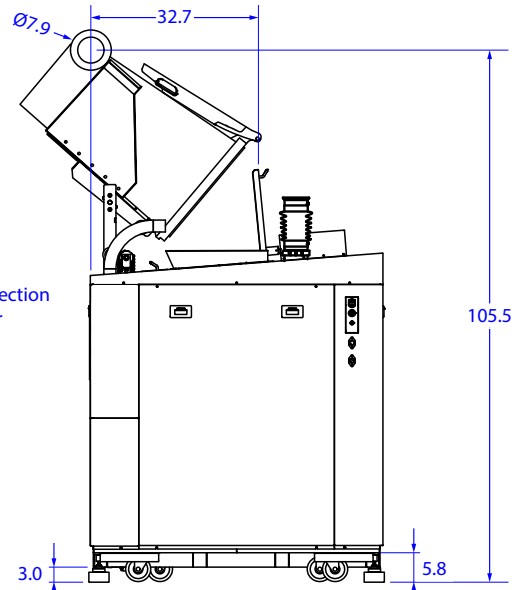

Right with bin fully lifted

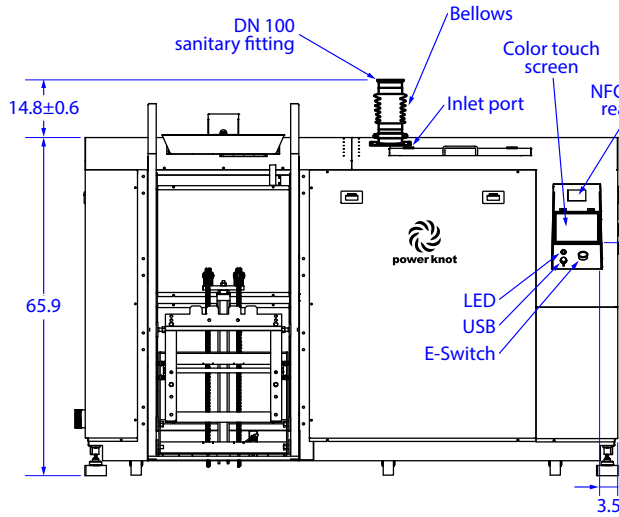

Front

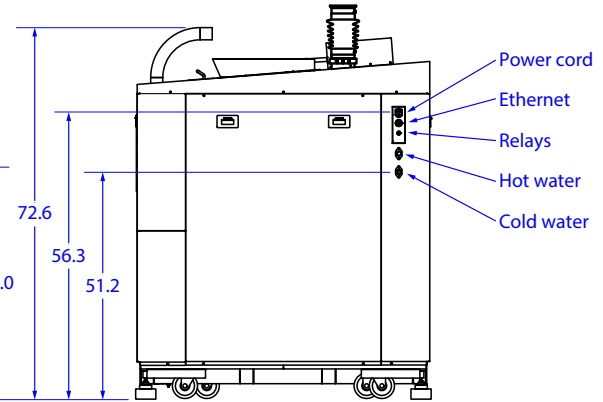

Right

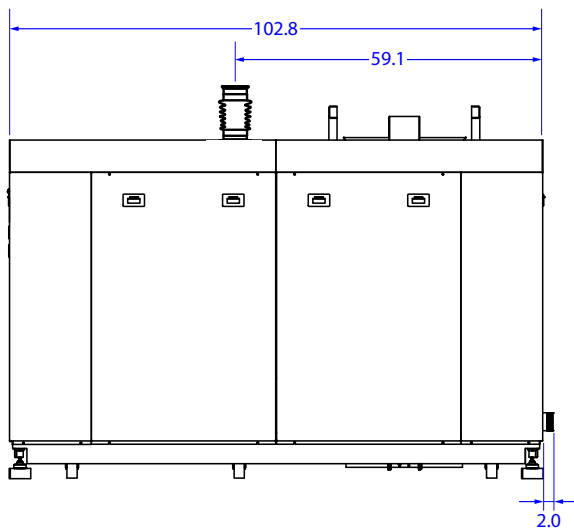

Back

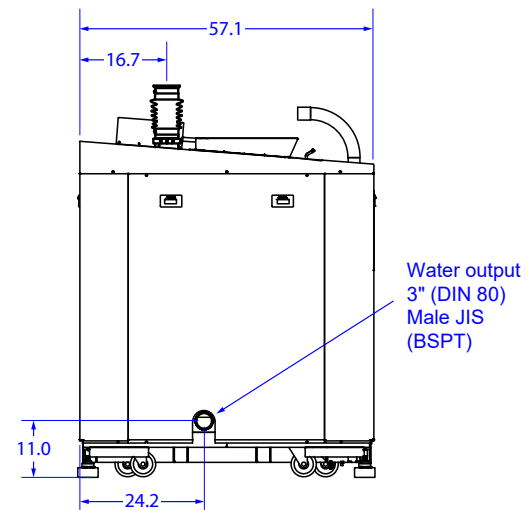

Left



Power Knot LLC | 47613 Warm Springs Blvd | Fremont, CA 94539 USA | +1-408-889-8433 | info@powerknot.com | www.powerknot.com

Power Knot, the Power Knot logo, the Power Knot mark, LFC, LFC Cloud, Powerchips, and Powerzyme are trademarks or registered trademarks of Power Knot LLC. All other trademarks used herein are the property of their respective owners. Copyright © 2009–2026 Power Knot LLC; all rights are reserved. Specifications are subject to change at any time without notice. Document number 96-01040-45, 21 April 2026.