

GSM Box

For industrial communications



About

The Power Knot GSM Box allows you to connect equipment that has an Ethernet port to the internet without using your own facility network.

The box contains a GSM modem and optionally and Ethernet switch to provide one or four Ethernet ports for your equipment. By using the GSM phone network you are assured that no data to or from your equipment can possibly corrupt or interfere with the data and servers on the network internal to your facility.

This box is ruggedly constructed for applications in harsh environments and is splash proof and dust proof. You can mount it on the wall, in a rack, or on a shelf. LEDs on the front clearly indicate the state of the communications.

The antenna is external to the box to allow you to place it in an optimum location even if there is no GSM signal or poor GSM signal at the location where you place the box itself.

The ac power is universal with an IEC connector allowing operation in most parts of the world.

Power Knot designs, develops, and assembles our products in Silicon Valley, California. Products are sold and serviced globally.



Features

- Internal GSM modem to operate in most parts of the world
- Uses standard SIM card
- Internal Ethernet switch can optionally provide four Ethernet ports
- Universal ac power to operate in most parts of the world
- LEDs at front give clear indication of operational status
- SIM card can be changed from the front but is protected by bolts

Benefits

- Allows communications to the internet without passing through your facility's network
- Box can be bolted to a wall or shelf to ensure stability
- Box can be mounted where convenient and antenna can be placed where the strongest signal is obtained
- Permanent mounting discourages theft
- One unit can serve multiple machines

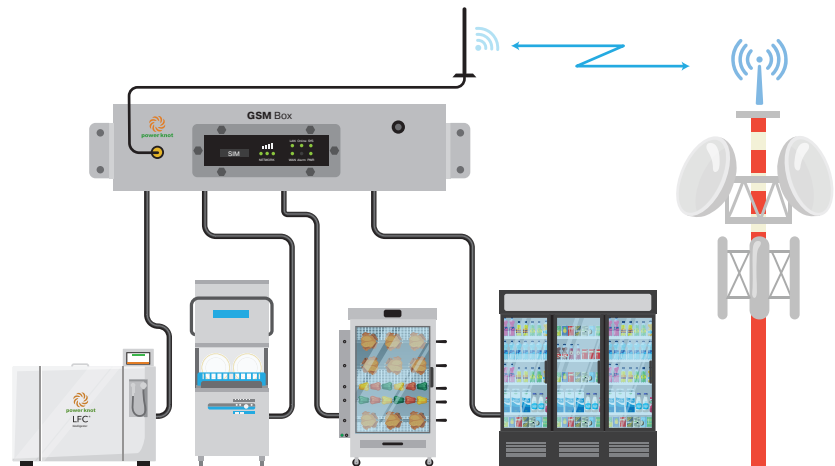

Example of usage with LFC biodigester

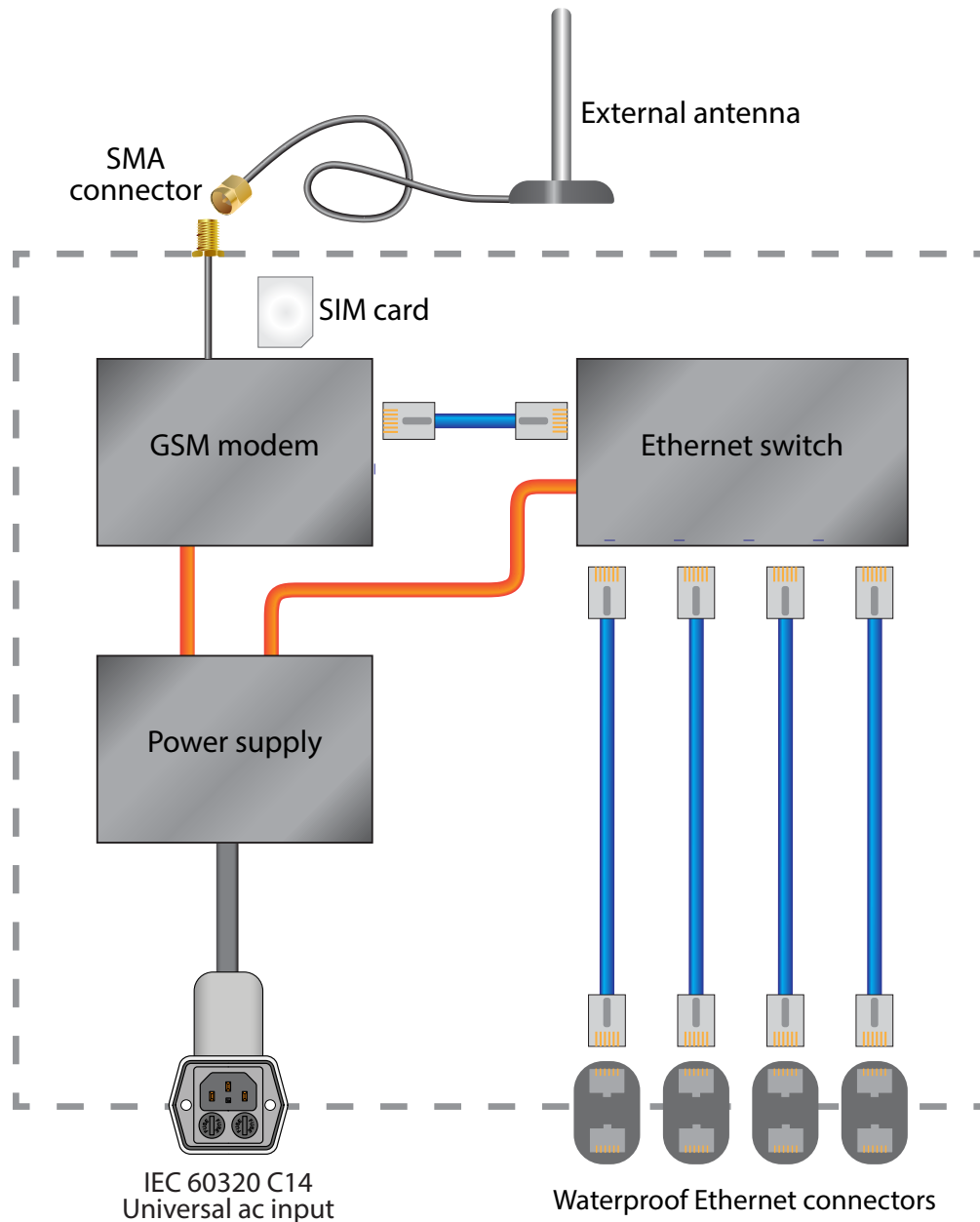

Dimensions

210 mm (w) x 255 mm (d) x 75 mm (h) (8.3" x 10.0" x 3.0")

Weight

3.2 kg (7.0 lb) with four Ethernet ports

Construction

All stainless steel

Operating environment

Indoors or covered patio
Must not be exposed to rain, snow, or sunshine

Ingress protection

IP54 – splash proof and dust proof

Operating conditions

Ambient temperature: 0°C to 40°C (50°F to 104°F)
Altitude: –100 m to 3000 m (9800 ft)

AC supply

100 V to 240 V, 50 Hz to 60 Hz
IEC 60320-1 C14 socket
Single phase + PE
External circuit breaker: 5 A

Antenna

Female SMA on box
Magnetic antenna with 2 m cable supplied



Power Knot LLC | 47613 Warm Springs Blvd | Fremont, CA 94539 USA | +1-408-889-8433 | info@powerknot.com | www.powerknot.com

Power Knot, the Power Knot logo, the Power Knot mark, LFC, and LFC Cloud are trademarks or registered trademarks of Power Knot LLC. All other trademarks used herein are the property of their respective owners. Copyright © 2009–2025 Power Knot LLC; all rights are reserved. Specifications are subject to change at any time without notice. Document number 96-01239-04; revised 17 March 2025.